



# Instruction Manual

## IEPE Supply Module M28

### Application

The IEPE Supply Module M28 is designed to connect piezoelectric sensors to measuring instruments or data acquisition systems which do not have IEPE compatible inputs. It supplies the power for the sensor electronics and de-couples DC components from the sensor signal. The M28 can be combined with the IEPE Conditioning Module M32 featuring additionally selectable gain and low pass filtering. The M28 is suited for both benchtop applications and DIN rail attachment in switch cabinets. The wide supply voltage range of the M28 allows power supply from external batteries, from a mains plug adapter or from an industrial 24 VDC supply.

Figure 1 shows the principle circuit diagram. The integrated sensor electronics is supplied with constant current. This should not be confused with a 4-20 mA current loop. The constant current  $I_{const}$  is fed into the signal cable of the sensor. A de-coupling capacitor  $C_C$  keeps DC components away from the input of the connected instrument.

Providing the constant current supply and de-coupling the output is the purpose of the IEPE Supply Module M28.

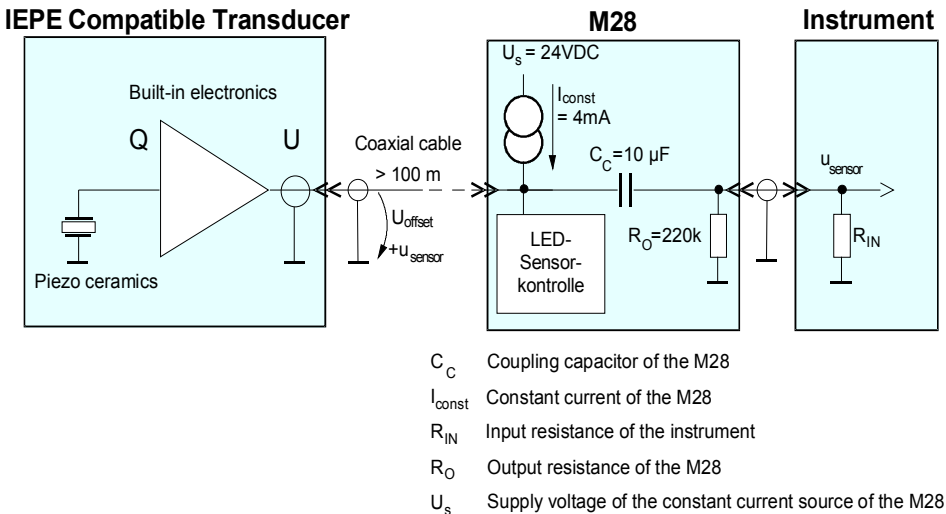

Figure 1: IEPE principle and functional diagram of the M28

# What is IEPE?

IEPE is a well-established standard for the output of piezoelectric transducers and microphones. It stands for "Integrated Electronics Piezo Electric". Other brand names for the same principle are ICP<sup>®</sup>, Isotron<sup>®</sup>, Delta-tron<sup>®</sup>, Piezotron<sup>®</sup> etc. By supplying the sensor with constant current, a positive DC offset voltage arises at the sensor output. This DC voltage depends on the manufacturer and the specimen and reaches 5 V to 14 V. Round this bias voltage the measuring signal of the transducer may oscillate. The output voltage of the transducer never changes to negative values. Its minimum value is the saturation voltage of the integrated electronics (about 1V). The maximum value of the output voltage is limited by the supply voltage of the constant current source (24 VDC with the M28). Figure 2 shows the dynamic range of the transducer. The output of the M28 is free of DC components. It provides the unaltered AC sensor output signal.

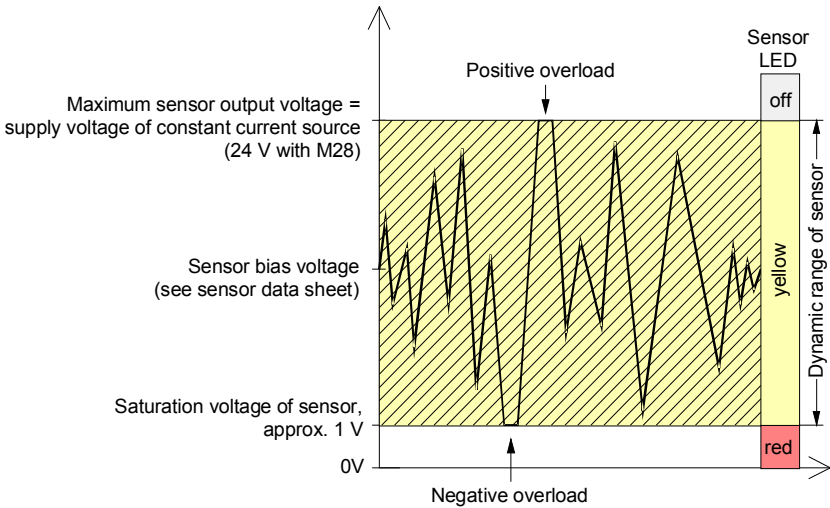

Figure 2: Dynamic range of IEPE sensors

# Description

The IEPE Supply Module M28 (Figure 3) contains the electronic circuit for supplying one sensor. For multichannel applications additional M28 modules can be plugged into one another by means of screwed in banana plugs at the side wall of the instrument. These plugs connect the power supply voltage to all modules.

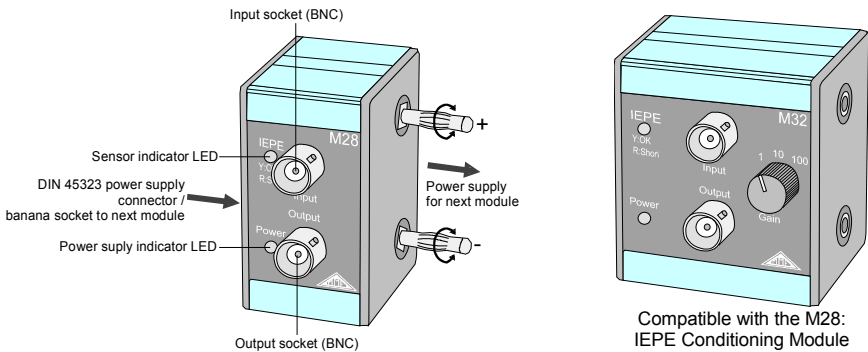

Figure 3: Functions of the M28

Compatible with the M28:  
**IEPE Conditioning Module M32** with selectable gain and plug-in low pass filter

The M28 requires for operation a supply voltage between 5 and 26 VDC. It can be powered, for example, by:

- Industrial 24 VDC supplies
- The optionally available mains plug adapters **PS500** (for up to 3 M28) and **PS1000** (for up to 6 M28)
- Batteries with more than 5 VDC
- PC or USB voltage (5 or 12 VDC)

The operating voltage is connected via a circular power connector to DIN 45323 on the left side of the M28. The tip (inner conductor) is the positive terminal. Alternatively the two banana sockets on the left side of the case can be used for power supply. Their polarity is shown in Figure 3. A green „Power“ LED indicates the connected supply voltage.

The M28 is protected against false polarization and line transients up to 60 V. Insulation between power supply and measuring signal is provided.

Internally a supply voltage of 24 VDC for the constant current source is generated. This voltage is sufficient for an optimal dynamic range with all available IEPE compatible transducers. The constant current of the M28 is approximately 4 mA.

An LED sensor status indicator informs the user of the following conditions: (compare Figure 2):

- LED off: No sensor connected or sensor circuit interrupted.
- LED yellow: Sensor connected properly with bias voltage between 1 and 24 VDC.
- LED red: Input shorted, voltage below 1 VDC.

The M28 is suited for applications with piezoelectric transducers over a frequency range from 0.1 Hz to 100 kHz. Thus seismic measurements at low frequencies with accelerometers or quasi static pressure and force measurements can be performed. Also shock measurements involving high frequencies and amplitudes are possible with the M28.

To reach the lower frequency limit of 0.1 Hz (-3 dB) the input resistance of the instrument connected to the output of the M28 must not be lower than 1 M $\Omega$ . At 100 k $\Omega$  input resistance the lower frequency limit will increase to approximately 0.3 Hz.

The M28 is well suited for 35 mm DIN rail attachment. For this purpose the adapter **M28+32DIN** is available as shown in Figure 4. The adapter base is mounted on the M28 by 2 screws M2.5. Two tapped holes are provided at the rear of the instrument. As second step the DIN rail bracket is attached by one screw M3.

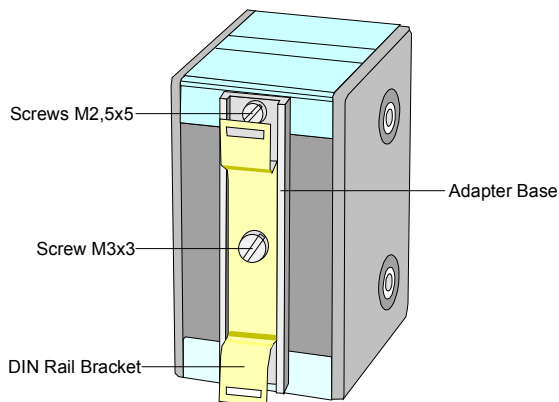

Figure 4: DIN Rail Adapter M28+32DIN

# Technical Data

Input / Output:	BNC sockets
Output circuit:	AC coupled over 10 $\mu$ F; 220 k $\Omega$ parallel with output Load resistance > 1 M $\Omega$ for lower frequency limit 0.1 Hz (-3 dB)
Dynamic range:	up to $\pm$ 10 V (depending on sensor type)
Constant current source:	3.8 .. 5.6 mA, compliance voltage >24 V
IEPE sensor status indicator:	bi-color LED; off = input open; yellow = 1 .. 24 V = OK; red = shorted
Gain / Accuracy:	1 $\pm$ 0,5 %
Output noise:	< 1 $\mu$ V <sub>rms</sub> (2 Hz .. 24 kHz)
Frequency range (- 3 dB):	0.1 Hz .. 100 kHz
Power supply:	U <sub>S</sub> = 5 .. 26 VDC; < 100 mA; insulated from signal path; via DIN 45323 circular power connector (positive terminal at tip) or two banana plugs
Case:	Aluminum, connected with negative supply terminal
Supplied accessories:	2 screw-in banana plugs for power supply connection with other modules
Optional accessories:	<b>PS500:</b> mains plug adapter for 100 .. 240 VAC; 12 VDC / 500 mA sufficient for up to 3 units M28 <b>PS1000:</b> mains plug adapter for 100 .. 240 VAC; 12 VDC / 1000 mA sufficient for up to 6 units M28 <b>M28+32DIN:</b> 35 mm DIN rail adapter
Operating temperature range:	-10 .. 55 °C; 95 % relative humidity; no condensation
Weight:	120 g
Dimensions (W x H x D):	33 mm x 59 mm x 44 mm

## Limited Warranty

Metra warrants for a period of  
**24 months**

that its products will be free from defects in material or workmanship and shall conform to the specifications current at the time of shipment.

The warranty period starts with the date of invoice.

The customer must provide the dated bill of sale as evidence.

The warranty period ends after 24 months.

Repairs do not extend the warranty period.

This limited warranty covers only defects which arise as a result of normal use according to the instruction manual.

Metra's responsibility under this warranty does not apply to any improper or inadequate maintenance or modification and operation outside the product's specifications.

Shipment to Metra will be paid by the customer.

The repaired or replaced product will be sent back at Metra's expense.



## Declaration of Conformity

Product: IEPE Supply Module

Model: M28

It is hereby certified that the above mentioned product complies with the demands pursuant to the following standards:

- EN 50081-1
- EN 50082-1

Responsible for this declaration is the producer  
Metra Mess- und Frequenztechnik in Radebeul e.K.

Meißner Str. 58  
D-01445 Radebeul

Declared by  
Manfred Weber  
Radebeul, 2<sup>nd</sup> of July, 1999